

FRONT WIPER MOTOR

COMPONENTS

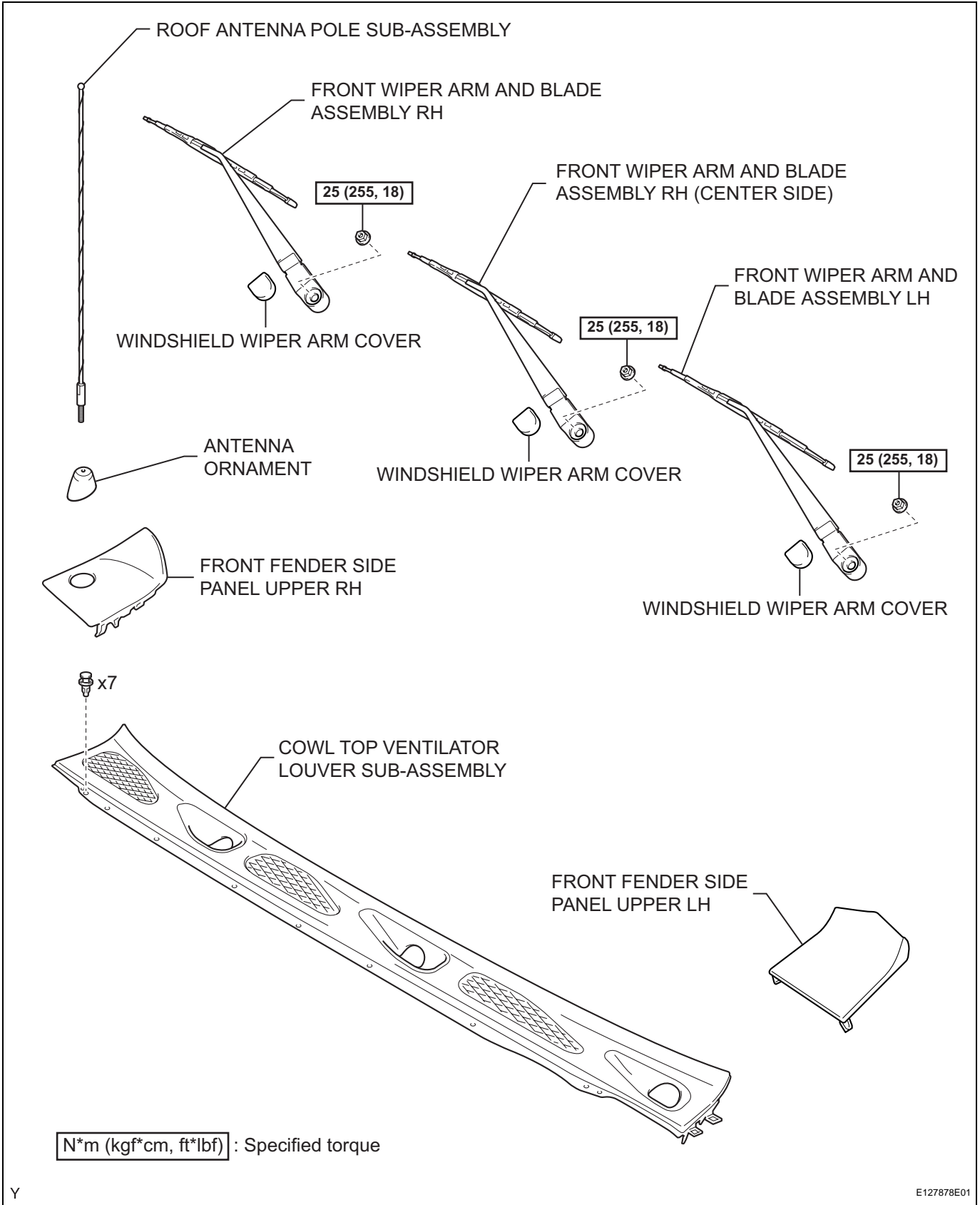

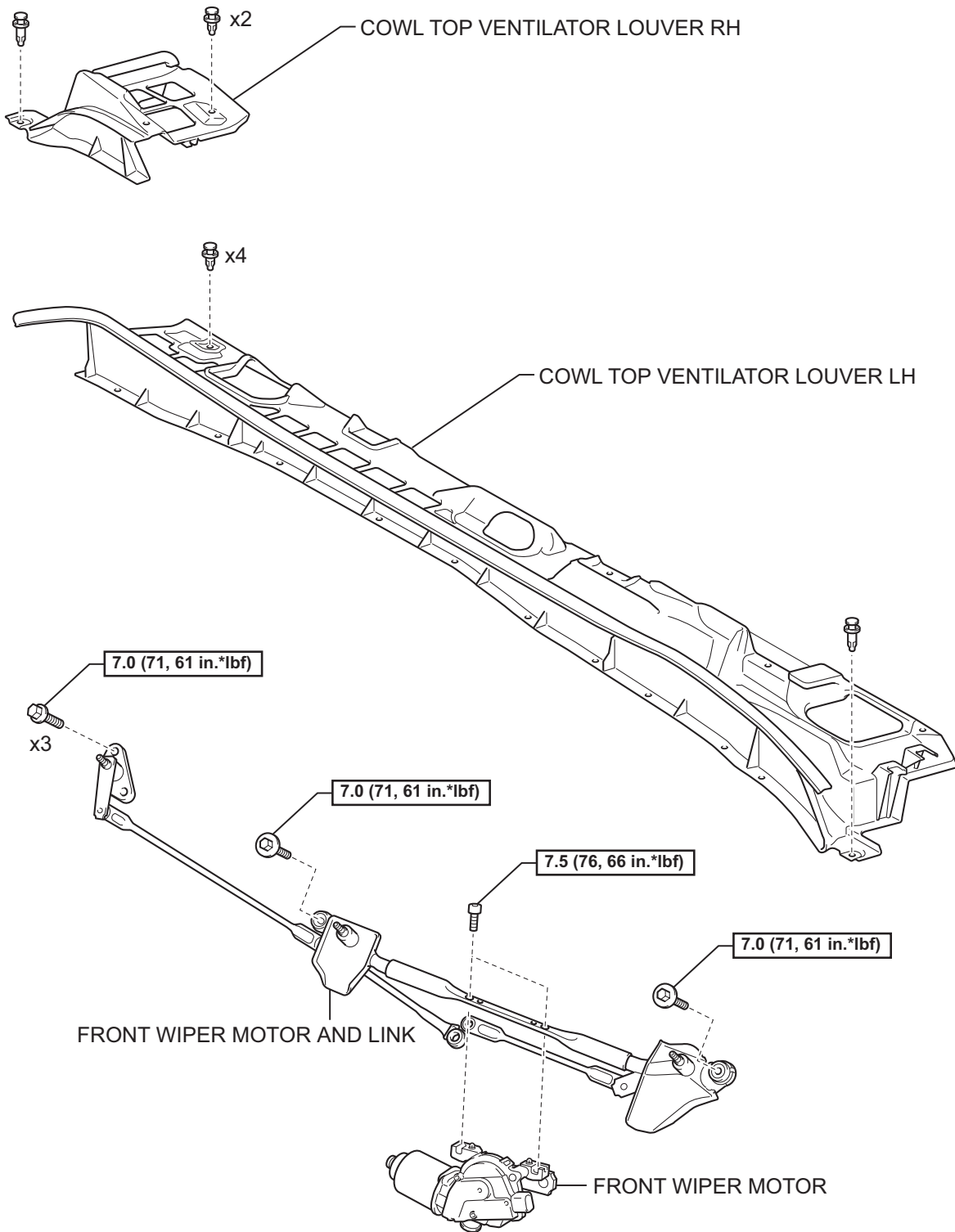

WW

N*m (kgf*cm, ft*lbf) : Specified torque

ON-VEHICLE INSPECTION**1. INSPECT FRONT WIPER MOTOR**

- (a) Check the automatic stop position.
 - (1) Operate the front wiper motor, then stop the operation.
 - (2) Check the automatic stop position when the front wiper motor operation has stopped.

Standard:

Front wiper arm stops in the position shown in the illustration.

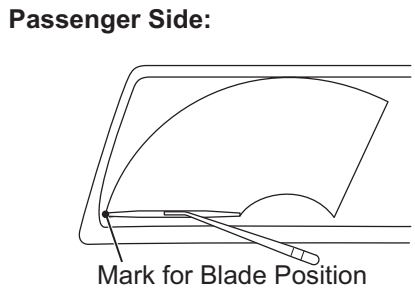
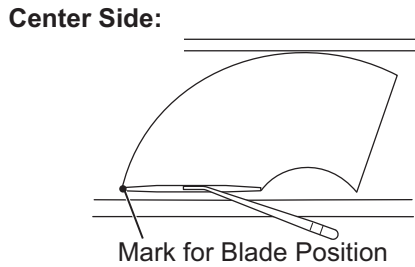
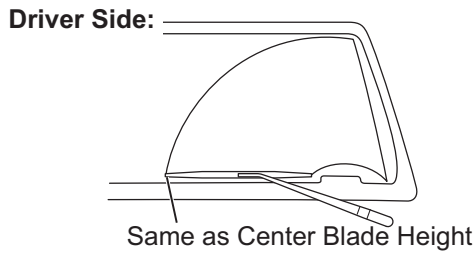

Y

E127857E01